

Forces and motion
Force Diagrams

A force diagram is a diagram showing all the forces acting on an object. Each force is shown as an arrow pointing in the direction in which the force acts. Force diagrams are used to model problems involving forces.

Example 1: A block of weight W is being pulled to the right by a force, P , across a rough horizontal plane. Draw a force diagram to show all the forces acting on the block.

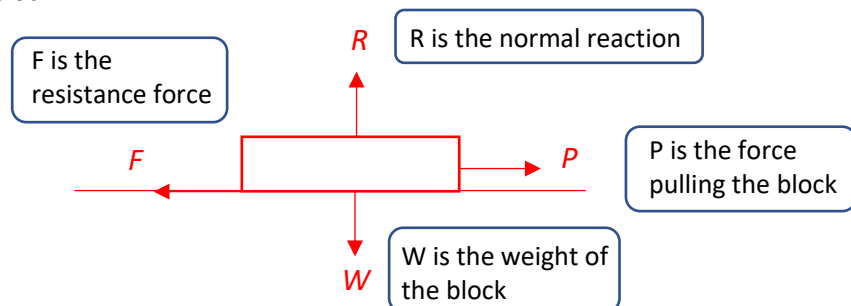

When the forces acting upon an object are balanced, the object is said to be in equilibrium. You can find the resultant force by adding forces acting in the same direction and subtracting forces in opposite directions.

Newton's first law of motion states that an object at rest will stay at rest and that an object moving with constant velocity will continue to move with constant velocity unless an unbalanced force acts on the object.

A resultant force will cause the object to accelerate in the same direction as the resultant force.

Example 2: The diagram shows the forces acting on a particle.

- Draw the resultant force.
- Describe the motion of the particle.
The particle is accelerating upwards.

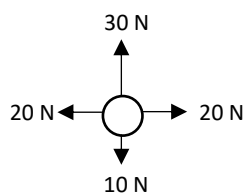
Forces as vectors

Forces can be written as vectors using i - j notation or as column vectors. Resultant of 2 or more forces can be given as vectors by adding the vectors. An object in equilibrium has a resultant vector force of $0i + 0j$.

Example 3: The forces $2i + 3j$, $4i - j$, $-3i + 2j$ and $ai + bj$ act on an object which is in equilibrium. Find the values of a and b .

$$(2i + 3j) + (4i - j) + (-3i + 2j) + (ai + bj) = 0$$

$$(2 + 4 - 3 + a)i + (3 - 1 + 2 + b)j = 0$$

$$\Rightarrow 3 + a = 0 \quad \text{and} \quad 4 + b = 0$$

$$\Rightarrow a = -3 \quad \text{and} \quad b = -4$$

Forces and acceleration

Newton's second law of motion states that the force needed to accelerate a particle is equal to the product of the mass of the particle and the acceleration produced: $F = ma$

Gravity is the force between any object and the Earth. The force due to gravity acting on an object is called the weight of the object, acting vertically downwards. A body falling freely experiences an acceleration of $g = 9.8 \text{ ms}^{-2}$. Hence, free fall objects have equations of $W = mg$.



Example 4: In the diagram below, the body is accelerating as shown. Find the magnitudes of the unknown forces X and Y .

- Horizontal forces:
 $X - 4 = 2 \times 2$
 $X = 8 \text{ N}$
- Vertical forces:
 $Y - 2g = 2 \times 0$
 $Y = 2(9.8)$
 $Y = 19.6 \text{ N}$

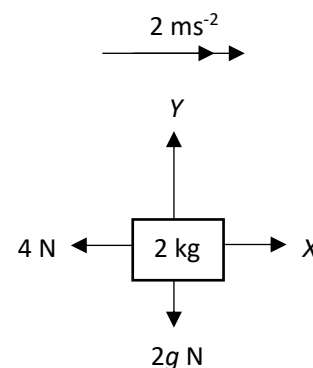
Motion in 2 dimensions

You can use $F = ma$ to solve problems involving vector forces acting on particles.

Example 5: In this question i represents the unit vector due east, and j represents the unit vector due north. A resultant force of $(3i + 8j) \text{ N}$ acts upon a particle of mass 0.5 kg .

- Find the acceleration of the particle in the form $(pi + qj) \text{ ms}^{-2}$.
 $F = ma$
 $(3i + 8j) = 0.5 \times a$
 $a = 2(3i + 8j)$
 $a = (6i + 16j) \text{ ms}^{-2}$
- Find the magnitude and the bearing of the acceleration, a , of the particle.
 $|a| = \sqrt{6^2 + 16^2} = 2\sqrt{73} = 17.1 \text{ (1 d.p.)}$
 $\tan \theta = \frac{16}{6} \text{ so } \theta = 69.4^\circ \text{ (1 d.p.)}$
So the bearing of the acceleration is

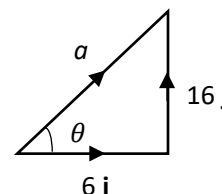

$$90^\circ - 69.4^\circ = 020.6^\circ$$

Remember bearings are always measured clockwise from north

Connected particles

If a system involves the motion of more than one particle, the particles may be considered separately. However, if all parts of the system are moving in the **same straight line**, then you can also treat the whole system as a single particle.

Example 6: Two particles, P and Q , of masses 5 kg and 3 kg respectively, are connected by a light inextensible string. Particle P is pulled by a horizontal force of magnitude 40 N along a rough horizontal plane. Particle P experiences a frictional force of 10 N and particle Q experiences a frictional force of 6 N .

- Find the acceleration of the particles
For the whole system:
All horizontal forces:
 $40 - 10 - 6 = 8a$
 $8a = 24$
 $a = 3 \text{ ms}^{-2}$

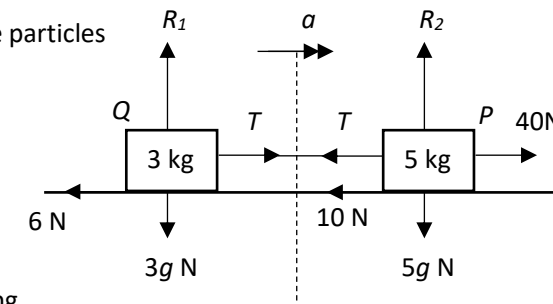

- Find the tension of the string
For P (horizontal forces):
 $40 - T - 10 = 5 \times 3$
 $T = 15 \text{ N}$

Newton's third law states that for every action there is an equal and opposite reaction.

Pulleys

A system with a smooth pulley means the tension of the string is the same on both sides of the pulley. You cannot treat a pulley system as a single particle as these particles move in opposite directions.

Example 7: Particles P and Q , of masses $2m$ and $3m$, are attached to the ends of a light inextensible string. The string passes over a small smooth fixed pulley and the masses hang with the string taut. The system is released from rest.

Find the acceleration of each mass.

$$\text{For P: } T - 2mg = 2ma$$

$$\text{For Q: } 3mg - T = 3ma$$

To find acceleration, both equations P and Q should be added together:

$$3mg - T + T - 2mg = 3ma + 2ma$$

$$mg = 5ma$$

$$\frac{1}{5}g = a$$

$$\frac{1}{5}(9.8) = a$$

$$a = 1.96 \text{ ms}^{-2} \approx 2.0 \text{ ms}^{-2} \text{ (2 s.f.)}$$

