



Topic Test: OxfordAQA
International A level Physics
Energy Sources

Name: _____

Class: _____

Date: _____

Time: **58 minutes**

Marks: **38 marks**

Comments:

1

Figure 1 shows a satellite with three solar panels folded in close to the satellite's axis for the journey into space in the hold of a cargo space craft.

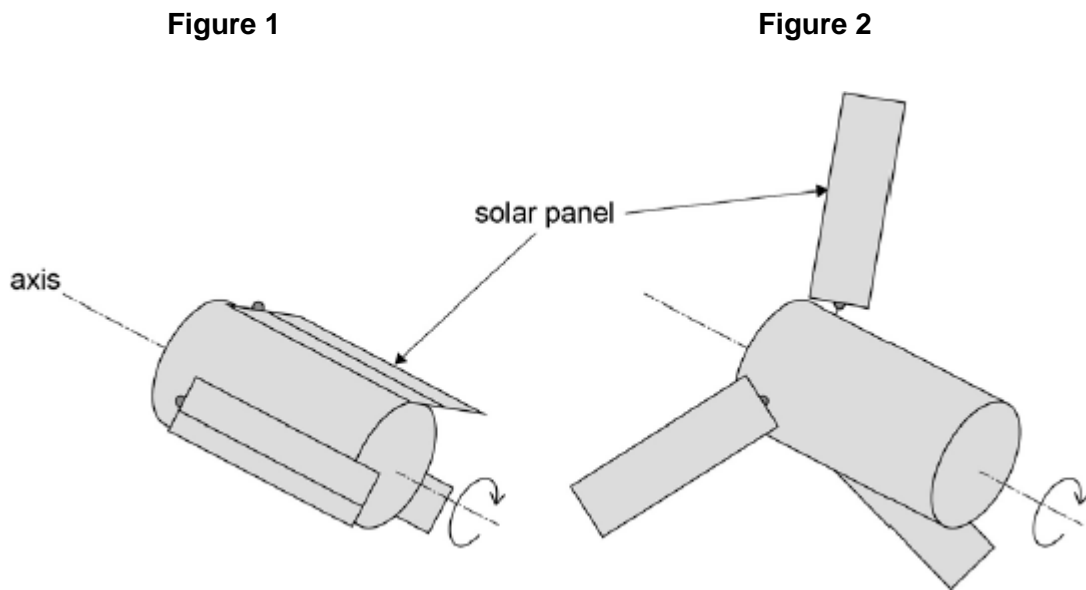

Just before it is released into space, the satellite is spun to rotate at 5.2 rad s^{-1} . Once released, the solar panels are extended as shown in **Figure 2**.

moment of inertia of the satellite about its axis with panels folded = 110 kg m^2

moment of inertia of the satellite about its axis with panels extended = 230 kg m^2

(a) State the law of conservation of angular momentum.

(1)

(b) The total mass of the satellite is 390 kg and the solar panels each have a mass of 16 kg.

State what is meant by moment of inertia and explain why extending the solar panels changes the moment of inertia of the satellite by a large factor.

(3)

- (c) Calculate the angular momentum of the satellite when it is rotating at 5.2 rad s^{-1} with the solar panels folded. State an appropriate unit for your answer.

angular momentum = _____ unit _____

(2)

- (d) Calculate the angular speed of the satellite after the solar panels have been fully extended.

angular speed = _____ rad s^{-1}

(2)

(Total 8 marks)

2

To power a small village at peak times requires a mean power of 450 kW.

An engineer suggests two options for providing the power. The first is a wind turbine and the second is a bank of solar cells.

- (a) (i) The efficiency of the wind turbine is 20%. Assuming a wind speed of 8.0 m s^{-1} calculate the length of the blades of the turbine that would be needed.

density of air = 1.30 kg m^{-3}

length of blades _____ m

(4)

- (ii) A solar cell has an efficiency of 20%. The average intensity of the Sun's radiation is 210 W m^{-2} . Assuming that the Sun's radiation falls normally on the solar cells, calculate the area of solar cells that would provide a mean power output of 450 kW.

area _____ m^2

(2)

- (b) To provide a useful supply, a bank of solar cells consists of many cells connected in a series and parallel array. The diagram below shows the principle using a smaller number of cells than is used in practice.

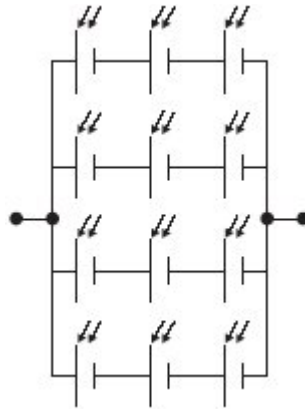

- (i) What is the advantage of connecting the cells in series?

(1)

- (ii) Explain the advantage of connecting the cells in parallel.

(2)

- (c) Even if both of the proposed supplies are installed and in working order there may still be no power available.
Explain why this could happen and what might be done to provide suitable back-up power.

(2)

(Total 11 marks)

3

- (a) A conventional hydroelectric power station has a power output of 9.0×10^7 W.
The height difference between its reservoir and its turbine unit is 610 m.
Assuming that the generation process is 95% efficient, calculate the mass of water passing through the turbine unit per second.

mass per second _____ kg s^{-1}

(4)

- (b) (i) The power station has an average annual output of 180GW h of electrical energy.
Calculate, in hours, the average time during which the power station is in operation per day.

average time _____ hours

(3)

- (ii) Without considering energy losses, explain why this power station is unable to produce significantly more than 180GW h of electrical energy per year.

(1)

4

Wind turbine **P** has blades of length 5.0 m. It produces an electrical power output of 15 kW when the wind speed is 30 km hour⁻¹.

Wind turbine **Q** has blades of length 6.0 m and operates in a wind of speed 25 km hour⁻¹. Wind turbine **Q** has the same efficiency as wind turbine **P** under these conditions.

What is the electrical power output of wind turbine **Q**?

- A 6.0 kW
- B 7.2 kW
- C 10.4 kW
- D 12.5 kW

(Total 1 mark)

5

The diagram shows an experiment in which a light sensor can be moved along the line **PQR** from a fixed light source. The intensity of light at **Q** is I .

What is the intensity at **P**?

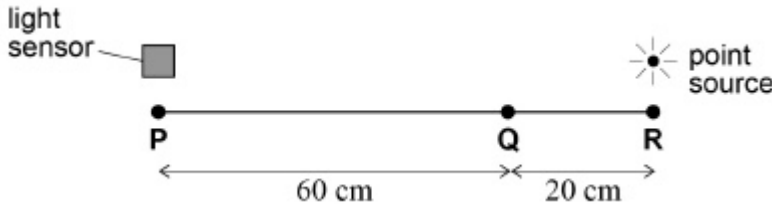

- A $\frac{I}{16}$
- B $\frac{I}{9}$
- C $\frac{I}{4}$
- D $\frac{I}{3}$

(Total 1 mark)

6

The graph shows the V–I characteristic for an array of solar panels.

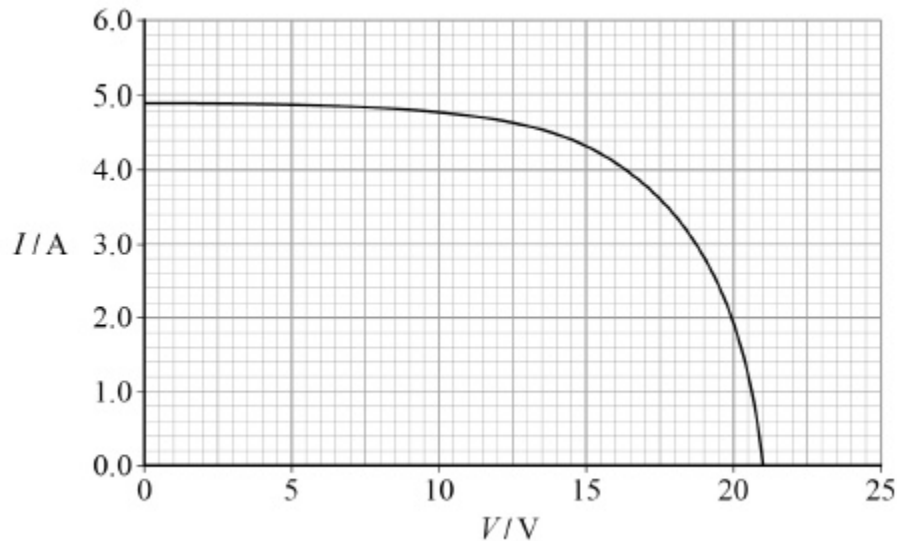

Which row gives the correct emf and maximum power available for the array?

	Emf / V	Maximum power available / W	
A	16	66	<input type="radio"/>
B	16	103	<input type="radio"/>
C	21	66	<input type="radio"/>
D	21	103	<input type="radio"/>

(Total 1 mark)

7

What is an advantage of pumped storage systems?

- A** They have efficiencies greater than one because they use energy that would otherwise be wasted.
- B** Electricity can be generated rapidly by the system at times of peak demand.
- C** Sites for development of pumped storage systems are available in most geographical locations.
- D** Response times for starting and stopping production are similar to those of nuclear power stations.

(Total 1 mark)

8

In a particular design of pumped storage station, water is pumped from a lower reservoir to an upper reservoir, both of fixed volume. The table shows data for two such stations, **X** and **Y**.

	Station X	Station Y
Volume of lower reservoir	$2V$	$5V$
Volume of upper reservoir	$3V$	$4V$
Vertical distance between upper and lower reservoir	$2h$	h
Maximum energy that can be stored by pumping water from the lower reservoir to the upper	E_X	E_Y

What is the ratio $\frac{E_X}{E_Y}$?

A $\frac{2}{5}$

B $\frac{3}{4}$

C 1

D 2

(Total 1 mark)

Mark schemes

1

- (a) The (total) angular momentum (of a system) remains constant provided no external torque acts (on the system) ✓

Do not accept 'force' in place of 'torque'

1

- (b) I is the sum of the $m r^2$ products for point masses m at radius r ✓

Or WTTE

Not m is the mass and r the radius – must refer to point or small masses or distribution of mass

OR

$\Sigma m r^2$ with m and r defined

OR

I is a measure of the mass and the way the mass is distributed about an axis

1

More of the satellite's mass is at greater radius ✓

1

(Small change in r) gives large change in r^2 , hence large change in I

OR even though m of panels is small, much of m is at a greater radius and radius is squared ✓

For 2nd mark must refer to effect of r^2 .

1

- (c) Angular momentum = $110 \times 5.2 = 572$ ✓

1

N m s **OR** $\text{kg m}^2 \text{s}^{-1}$ ✓

accept

$\text{kg m}^2 \text{rad s}^{-1}$

1

- (d) (Use of conservation of ang momtm) $572 = 230 \times \omega_2$ ✓

1

$\omega_2 = 572 / 230 = 2.49 \text{ rad s}^{-1}$ ✓

1

[8]

2

(a) (i) energy input needed = 2250 kW **(1)**
(450 × 5 seen or implied in calculation)

B1

substitution in formula for r
(allow any power and condone incorrect power
for k) **(1)**

C1

correct substitution including correct power 10^3 for
k in kW **(1)**

C1

46(.4)m **(1)**

A1

(ii) area = $450000/210 = 2140 \text{ m}^2$ (i.e. forgets to use
efficiency factor) **(1)**

B1

10700m² **(1)** (ecf for input power needed from (i))

B1

6

(b) (i) emf from a cell is too low to power equipment **(1)**
or
to increase the emf of the supply (allow higher voltage)

B1

(ii) connecting cells in parallel lowers total resistance
or
show total resistance to be 3Ω

B1

currents from each parallel section add up at the
junction to the external circuit
or
output current increased

B1

3

if one cell is faulty the others still work/supply energy

(c) occasionally neither wind nor Sun's energy will be available **(1)**

B1

back up using (one of)

connection to mains supply **(1)**

local generator using non-renewable fuel

use(pumped) viable storage system

use source that does not rely on wind or sun

B1

2

[11]

3

(a) any attempted use of $mg\Delta h = \text{power}$ (or numerical equivalent)

C1

correct sub into $mg\Delta h = 9 \times 10^7$ or $(m/t =) 9 \times 10^7 / (9.81 \times 610)$
(condone power of 10) or correct use of efficiency (condone
power of 10)

C1

$(m/t =) 9 \times 10^7 / (0.95 \times 9.81 \times 610)$ seen or equivalent

C1

$(m/t =) 1.6 \times 10^4 / 15800$ (kg s^{-1})

A1

4

(b) (i) correct sub into $P = E/t$ ($t =$) $180 \div 0.09$ seen/
($t =$) $180 \times 10^9 \div 9 \times 10^7$ seen/or 2000 (h)/ 7.2×10^6 (condone
power of 10)

C1

(operating time per day =) $7.2 \times 10^6 / 365$ or $2000 / 365$

C1

5.48 or 5.5 (hours)

A1

3

(ii) limited amount of water (owtte)

B1

1

- (c) The marking scheme for this question includes an overall assessment for the quality of written communication (QWC). There are no discrete marks for the assessment of QWC but the candidate's QWC in this answer will be one of the criteria used to assign a level and award the marks for this question.

Descriptor – an answer will be expected to meet most of the criteria in the level descriptor.

Level 3 – good

- claims supported by an appropriate range of evidence
- good use of information or ideas about physics, going beyond those given in the question
- argument well-structured with minimal repetition or irrelevant points
- accurate and clear expression of ideas with only minor errors of grammar, punctuation and spelling

5–6

Level 2 – modest

- claims partly supported by evidence
- good use of information or ideas about physics given in the question but limited beyond this
- the argument shows some attempt at structure
- the ideas are expressed with reasonable clarity but with a few errors of grammar, punctuation and spelling

3–4

Level 1 – limited

- valid points but not clearly linked to an argument structure
- limited use of information about physics
- unstructured
- errors in spelling, punctuation and grammar or lack of fluency

1–2

Level 0

- incorrect, inappropriate or no response

Examples of the sort of information or ideas that might be used to support an argument:

Load balancing

- matching production to consumption
- energy continually produced by base load stations
- variation in demand

At peak demand

- water from lower reservoir to upper reservoir
- drives turbine – generator
- gpe to electrical

At low demand

- water from lower reservoir to upper reservoir
- pumps water
- electrical to gpe

Benefits

At low demand

- stores excess energy (otherwise stated)
- uses cheaper electricity

At peak demand

- releases energy very quickly
- saves using other more expensive peak stations
- less CO₂ emissions

Problems eg

- limited suitable sites
- damage to habitats/long transmission lines

[14]

4 D

[1]

5 A

[1]

6 A

[1]

7 B

[1]

8 C

[1]