



Cambridge Lower Secondary Checkpoint

CANDIDATE
NAME

CENTRE
NUMBER

--	--	--	--	--

CANDIDATE
NUMBER

--	--	--	--



MATHEMATICS

1112/02

Paper 2

April 2021

1 hour

You must answer on the question paper.

You will need: Geometrical instruments
 Tracing paper (optional)

INSTRUCTIONS

- Answer **all** questions.
- Use a black or dark blue pen. You may use an HB pencil for any diagrams or graphs.
- Write your name, centre number and candidate number in the boxes at the top of the page.
- Write your answer to each question in the space provided.
- Do **not** use an erasable pen or correction fluid.
- Do **not** write on any bar codes.
- You should show all your working in the booklet.
- You may use a calculator.

INFORMATION

- The total mark for this paper is 50.
- The number of marks for each question or part question is shown in brackets [].

This document has **16** pages. Any blank pages are indicated.

1 Here is a list of symbols.

< > =

Choose the correct symbol from the list for each of these statements.

3.7 3.65

4.035 4.34

7.6 7.60

[1]

2 Draw a ring around the value of the digit 4 in the number 6.354

$\frac{4}{10}$ $\frac{4}{100}$ $\frac{4}{1000}$ $\frac{4}{10000}$

[1]

3 Solve.

$$5x - 2 = 3(x + 4)$$

$x =$ [3]

4 Work out.

$$\frac{1+12^2}{2 \times 3^2 - 13}$$

..... [1]

5 A plane flies between two cities 1836 km apart.
It travels at an average speed of 850 km/h.

Calculate how long the flight takes.
Give your answer in hours.

..... hours [2]

6 Ten teams (A to J) entered a competition to build a model car using plastic bricks.

Competition rules:

- (1) The maximum number of batteries to power the model car is 6
- (2) The maximum mass of the model car is 1 kg.
- (3) The winner is the model car with the greatest speed.

The scatter graphs show some information about the model cars built by the 10 teams.

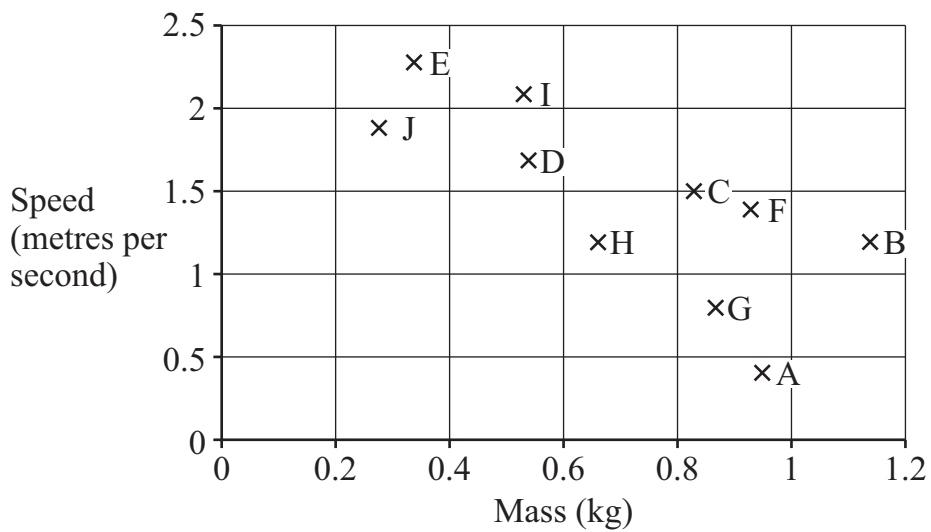
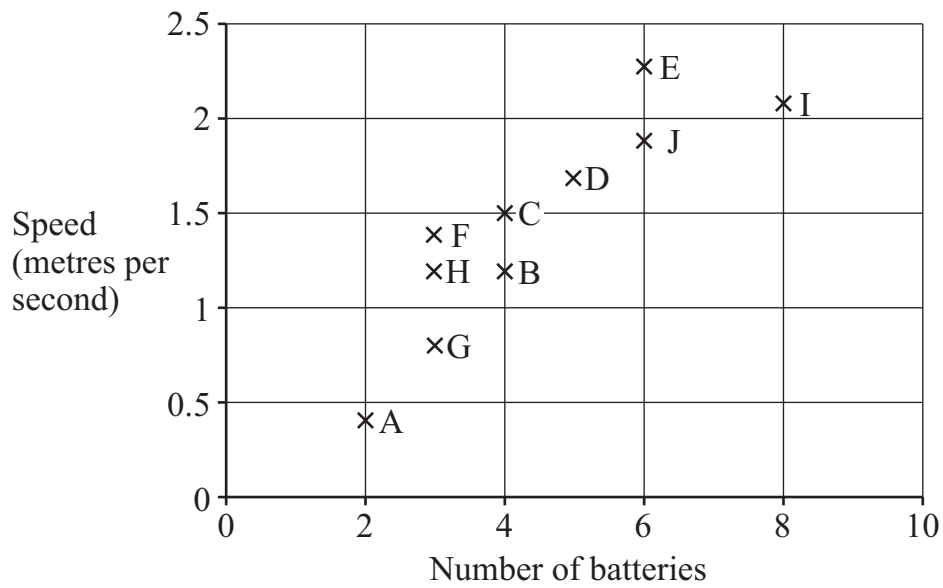

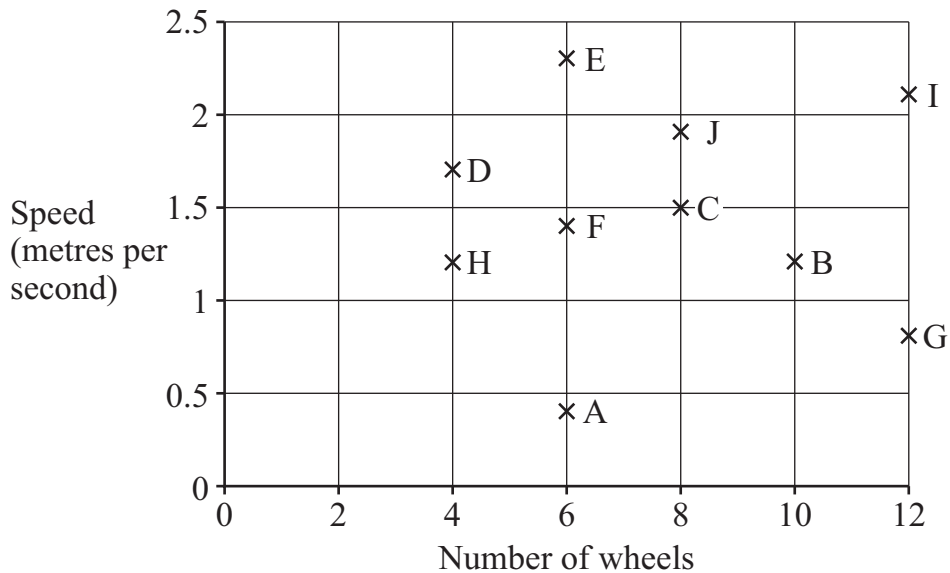

(a) Complete these sentences.

Team wins the competition.

Teams and are disqualified for breaking the competition rules.

[2]

(b) Complete these sentences to describe the type of correlation shown on these three graphs.

The graph of speed plotted against the number of batteries shows correlation.

The graph of speed plotted against the mass shows correlation.

The graph of speed plotted against the number of wheels shows correlation.

[2]

7 Draw the reflection of the triangle in line L.

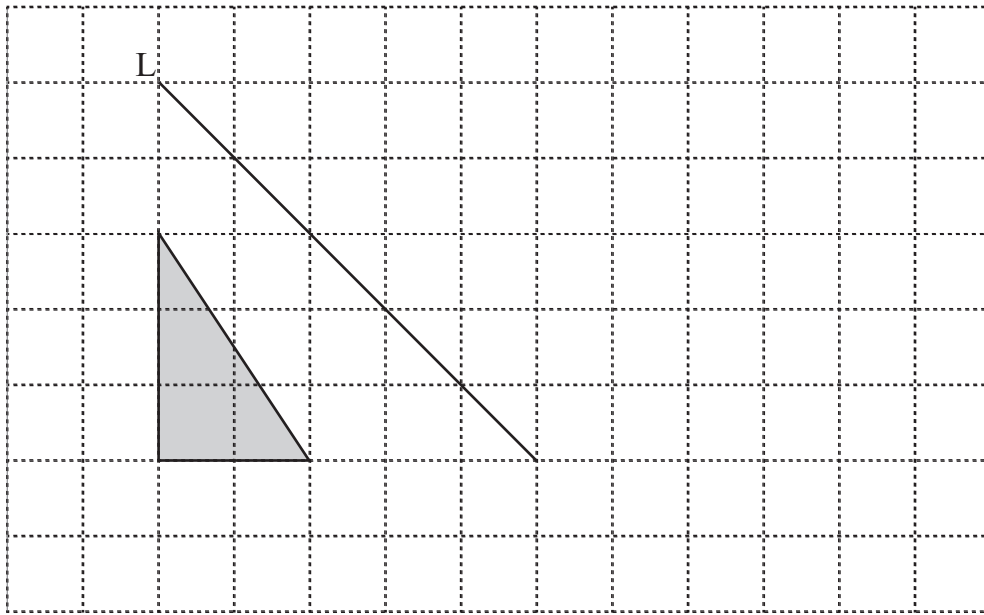

[1]

8 Gabriella's book has 348 pages.
She has read 163 of the pages.

Safia's book has 562 pages.
She has read 225 of the pages.



Tick (✓) to show who has read the greater proportion of their book.
Show all your working.

Gabriella

Safia

[2]

9 The table shows information about a sequence of patterns made from rods.

Diagram				
Pattern number	1	2	3	4
Number of rods	3	5	7	

(a) Draw the diagram for pattern number 4 in the table.

[1]

(b)

Choose two of these cards to complete the sentence describing the general term.

Number of rods needed = pattern number then

[1]

10 Draw a ring around all the numbers that are greater than $\frac{11}{16}$ and less than $\frac{15}{16}$

0.45 0.55 0.65 0.75 0.85 0.95

[1]

11 Complete this calculation.

$$4^2 = 2 \times (\text{ } + 3)$$

[1]

12 Write the ratio 75 cm : 1.8 m in its simplest form.

..... : [2]

13 Lily pours 5 litres of water into glasses.
Each glass holds 225 millilitres.

Calculate how many glasses Lily can fill completely.

..... [1]

14 Write 735 as the product of its prime factors.

..... [2]

15 Write the answer to each calculation correct to two decimal places.

Calculation	Correct to two decimal places
$45 \div 13$	
$103 \div 15$	
$17 \div 11$	

[2]

16 $ABCDEF$ is a hexagon.

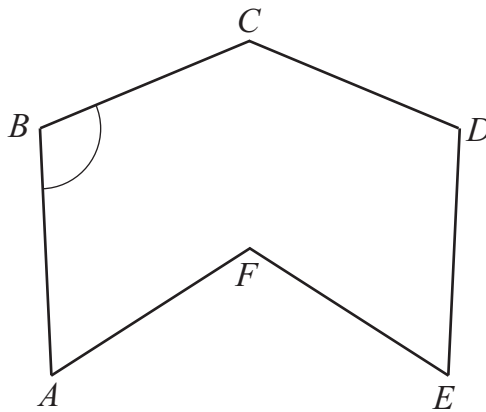

(a) Measure angle ABC .

..... [1]

(b) $ABCDEF$ is enlarged by scale factor 3.

Write down the size of angle ABC in the enlarged shape.

..... [1]

17 Angelique wants to find out how students in her class travel to school.

Design a **question** for her to find this data.
Include response boxes.

[2]

- 18 Some students choose their favourite drink from the six drinks shown in the table. Some of the probabilities of the students choosing each drink are shown.

Drink	Tea	Coffee	Milk	Water	Cola	Orange
Probability	0.15	0.32		0.08		0.29

Three times as many students choose milk as choose cola.

Complete the table.

[2]

- 19 The exchange rate from euros (€) to dollars (\$) is €1 = \$1.2

Complete these conversions.

€160 to dollars.

\$

\$76.80 to euros.

€

[2]

- 20 A farm has 150 hectares of land.

Write this area in square metres.

..... m² [1]

21 (a) Solve the inequality.

$$19 \leq 7 - 3x$$

..... [2]

(b) Represent the range of values for x on the number line.

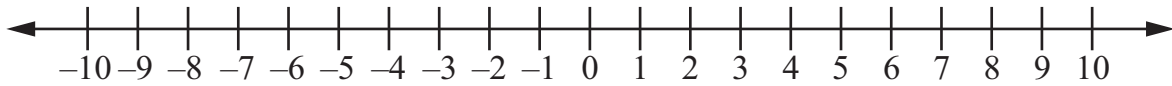

[1]

22 The original price of a television is reduced by 25%.
This new price is then increased by 25%.

Calculate the price of the television now as a percentage of the original price.

.....% [2]

23 The diagram shows a semicircle.

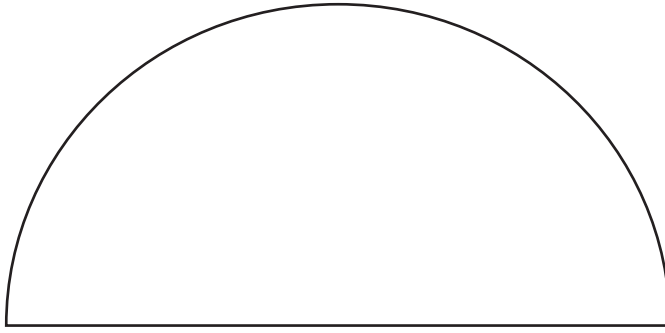

NOT TO
SCALE

The diameter of the semicircle is 12 cm.

Calculate the perimeter of the semicircle.

..... cm [2]

24 Here are two rectangles.

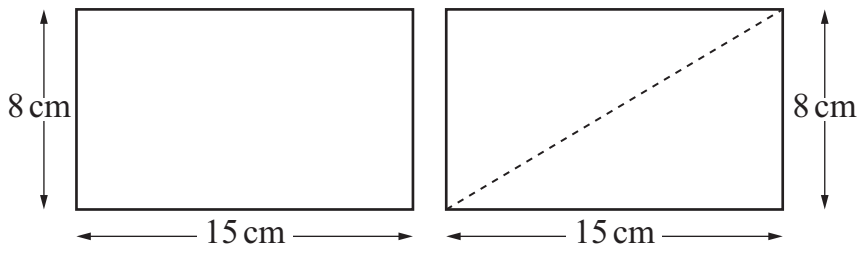

NOT TO SCALE

The second rectangle is cut in half and joined to the first rectangle to make a new shape.

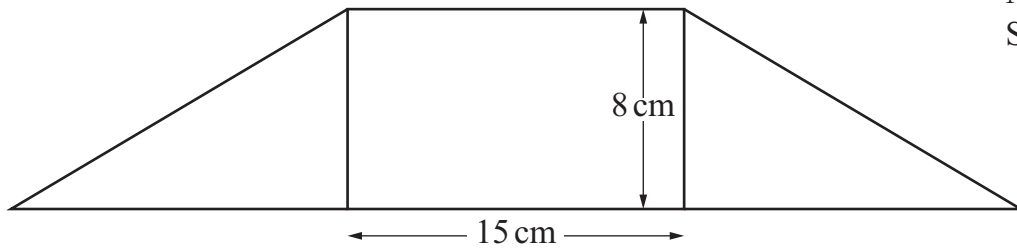

NOT TO SCALE

Calculate the perimeter of the new shape.

..... cm [2]

25 The table shows the number of music downloads bought by 35 students during a year.

Number of music downloads	Frequency
0 – 4	5
5 – 9	16
10 – 14	11
15 – 19	3
>19	0

Write down the modal class.

..... [1]

26 ■ and * are positive integers.

■ is a factor of 15

* is a multiple of 3

Write down the smallest possible answer to $\blacksquare \times *$.

..... [1]

27 Ahmed has a rod 2 metres long.

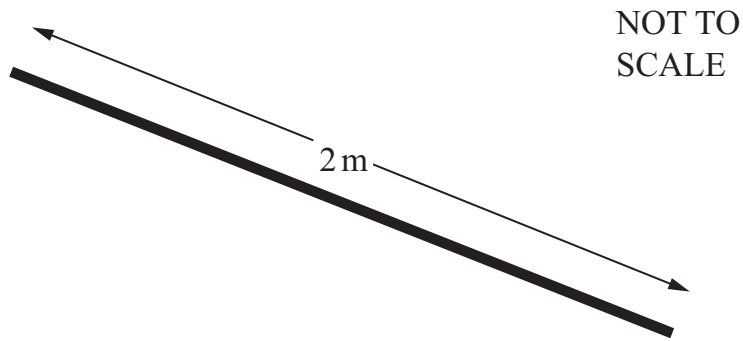

He cuts the rod into four pieces and uses them to make a rectangle.



The length of the rectangle is 3 times the width.

Calculate the area of the rectangle in **square centimetres**.

..... cm² [3]

28 Tick (✓) the expression that is closest to the square root of $3a^6$

$1.5a^2$

$1.5a^3$

$1.7a^2$

$1.7a^3$

$3a^3$

[1]

BLANK PAGE

Permission to reproduce items where third-party owned material protected by copyright is included has been sought and cleared where possible. Every reasonable effort has been made by the publisher (UCLES) to trace copyright holders, but if any items requiring clearance have unwittingly been included, the publisher will be pleased to make amends at the earliest possible opportunity.

To avoid the issue of disclosure of answer-related information to candidates, all copyright acknowledgements are reproduced online in the Cambridge Assessment International Education Copyright Acknowledgements Booklet. This is produced for each series of examinations and is freely available to download at www.cambridgeinternational.org after the live examination series.

Cambridge Assessment International Education is part of the Cambridge Assessment Group. Cambridge Assessment is the brand name of the University of Cambridge Local Examinations Syndicate (UCLES), which itself is a department of the University of Cambridge.