

OCR (B) Biology GCSE

Topic B5.1: How do substances get into,
out of and around our bodies?

Flashcards

Why do large multicellular organisms
require specialised exchange surfaces?

Why do large multicellular organisms require specialised exchange surfaces?

- Small SA/V ratio
- Diffusion insufficient to provide all cells with the required oxygen and nutrients, and to remove all waste products
- Exchange surfaces increase the rate of diffusion and shorten the diffusion distance

Why do some multicellular organisms
(e.g. trees) not require specialised
exchange surfaces?

Why do some multicellular organisms (e.g. trees) not require specialised exchange surfaces?

Trees have a large number of leaves which provide a large SA/V ratio for diffusion.

How does the size of an organism affect its surface area to volume ratio?

How does the size of an organism affect its surface area to volume ratio?

The larger the organism, the smaller the SA/V ratio.

Calculate the surface area to volume ratio of a cube that is $1 \times 1 \times 1$ cm

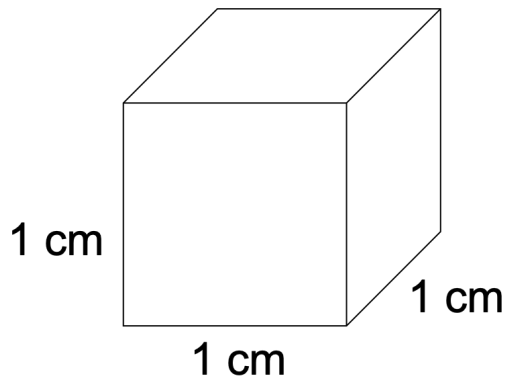

Calculate the surface area to volume ratio of a cube that is $1 \times 1 \times 1$ cm

$$\text{Surface area: } (1 \times 1) \times 6 = 6 \text{ cm}^2$$

$$\text{Volume: } 1 \times 1 \times 1 = 1 \text{ cm}^3$$

$$\text{Surface area : Volume} = \mathbf{6:1}$$

Calculate the surface area to volume ratio of a cuboid that is $2 \times 3 \times 4$ cm

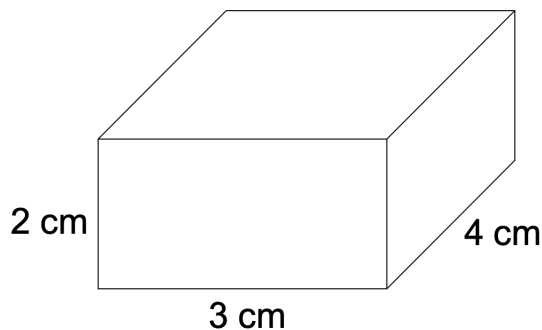

Calculate the surface area to volume ratio of a cube that is $2 \times 3 \times 4$ cm

Surface area:

$$2(2 \times 3) + 2(2 \times 4) + 2(4 \times 3) = 52 \text{ cm}^2$$

$$\text{Volume: } 2 \times 3 \times 4 = 24 \text{ cm}^3$$

$$\text{Surface area : Volume} = 52:24 = \mathbf{13:6}$$

Name some of the substances
transported into and out of the human
body

Name some of the substances transported into and out of the human body

- Oxygen
- Carbon dioxide
- Water
- Dissolved food molecules
- Urea

Why must the human body exchange oxygen and carbon dioxide with the environment?

Why must the human body exchange oxygen and carbon dioxide with the environment?

- Oxygen is required for respiration so diffuses into the body
- Carbon dioxide is a toxic waste product of respiration so diffuses out of the body

How does oxygen enter and carbon dioxide leave the bloodstream?

How does oxygen enter and carbon dioxide leave the bloodstream?

- Oxygen diffuses from air in the alveoli into blood in the capillaries
- Carbon dioxide diffuses from blood in the capillaries into air in the alveoli

How are alveoli adapted for gaseous exchange? (6)

How are alveoli adapted for gaseous exchange? (6)

- Large surface area
- Surrounded by a network of capillaries giving a good blood supply
- Rapid blood flow maintains a steep concentration gradient
- Thin walls so short diffusion distance
- Cell walls have partially permeable membranes enabling diffusion
- Walls covered by a thin, moist film, enabling gases to dissolve and increasing the rate of diffusion

Describe how water enters the bloodstream

Describe how water enters the bloodstream

It is absorbed into the bloodstream from the large intestine by osmosis.

Describe how water leaves the body

Describe how water is transported into and out of the body

It leaves the body in exhaled air, sweat and urine.

Why are food molecules required by the body?

Why are food molecules required by the body?

Required for the synthesis of biomass
and other reactions e.g. respiration

How do food molecules enter the bloodstream?

How do food molecules enter the bloodstream

They are absorbed into the bloodstream in the small intestine by active transport and diffusion.

How is the small intestine adapted for
the rapid absorption of food molecules?
(5)

How is the small intestine adapted for the rapid absorption of food molecules? (5)

Small intestine covered in villi (finger-like projections):

- Villi provide a large surface area
- Thin walls consist of a single layer of cells enabling rapid absorption and providing a short diffusion distance
- Cell walls have partially permeable membranes allowing diffusion
- Surrounded by a network of capillaries giving a good blood supply
- Rapid blood flow maintains a steep concentration gradient

Why must urea be excreted from the body?

Why must urea be excreted from the body?

It is a waste product so must be excreted.

How is urea excreted from the body?

How is urea excreted from the body?

- Urea diffuses out of cells into the blood plasma
- The kidney filters urea out of the blood
- Urea is excreted in urine

What is the circulatory system?

What is the circulatory system?

A network of organs and vessels that enables the flow of blood and transport of oxygen, carbon dioxide, nutrients and other molecules (e.g. hormones) around the body.

Describe the double circulatory system in humans

Describe the double circulatory system in humans

Blood flows through the heart twice in two circuits:

- Pulmonary circuit
- Systemic circuit

What is the pulmonary circuit?

What is the pulmonary circuit?

- Part of the circulatory system involving the right side of the heart
- Deoxygenated blood is transported to the lungs
- Gaseous exchange occurs between the alveoli and capillaries in the lungs
- Oxygenated blood is returned to the left side of the heart

What is the systemic circuit?

What is the systemic circuit?

- Part of the circulatory system involving the left side of the heart
- Oxygenated blood is pumped to tissues and organs around the body
- Exchange of materials occurs at tissues
- Deoxygenated blood returns to the right side of the heart
- The systemic circuit is connected to the digestive and excretory systems

Name the four chambers of the heart

Name the four chambers of the heart

- Left atrium
- Left ventricle
- Right atrium
- Right ventricle

Describe the pathway of blood around the body, naming the structures of the heart

Describe the pathway of blood around the body,
naming the structures of the heart

Pulmonary vein → Left atrium → Left ventricle →
Aorta → Body → Vena cava → Right atrium →
Right ventricle → Pulmonary artery → Lungs

What is the function of valves in the heart?

What is the function of valves in the heart?

Prevent the backflow of blood

Why is the left ventricle thicker than the right ventricle?

Why is the left ventricle thicker than the right ventricle?

- It pumps blood a further distance
- It must generate a greater force of contraction so blood can be pumped at a higher pressure

What is the function of the coronary arteries?

What is the function of the coronary arteries?

Supply heart muscle with oxygen and nutrients

What is the function of cardiac muscle?

What is the function of cardiac muscle?

Contracts to pump blood around the body

Describe how cardiac muscle is adapted to its function

Describe how cardiac muscle is adapted to its function

It contains many mitochondria to produce ATP for muscle contraction

What are the three main types of blood vessel?

What are the three main types of blood vessel?

- Arteries
- Capillaries
- Veins

What is the function of the arteries?

What is the function of the arteries?

Carry blood away from the heart under high pressure

Describe how the arteries are adapted to their function (6)

Describe how the arteries are adapted to their function (6)

- Narrow lumen maintains high pressure
- Thick wall to withstand high pressure
- Thick layer of smooth muscle provides strength
- Thick layer of elastic fibres allow stretch and recoil
- Smooth inner lining to reduce friction
- No valves

What is the function of the veins?

What is the function of the veins?

Return blood to the heart under low pressure

Describe how the veins are adapted to their function (4)

Describe how the veins are adapted to their function (4)

- Large lumen eases blood flow
- Thinner wall (blood at lower pressure)
- Thin layer of smooth muscle and elastic fibres
- Valves

What is the function of the capillaries?

What is the function of the capillaries?

Allow exchange of materials at tissues

Describe how the capillaries are adapted to their function (4)

Describe how the capillaries are adapted to their function (4)

- Form large network increasing the surface area for diffusion
- Thin walls (one cell thick) so short diffusion distance
- Walls permeable allowing the exchange of substances
- Narrow lumen decreases diffusion distance

What are the main components of blood?

What are the main components of blood?

- Red blood cells
- White blood cells
- Platelets

What is the function of red blood cells?

What is the function of red blood cells?

- Transport O_2 from the lungs to tissues
- Transport CO_2 from the tissues to lungs

How do red blood cells transport oxygen to body cells?

How do red blood cells transport oxygen to body cells?

- At the lungs, haemoglobin in red blood cells binds reversibly with oxygen to form oxyhaemoglobin
- At the tissues oxygen is released and diffuses into cells

How are red blood cells adapted to their function?

How are red blood cells adapted to their function?

- Lack nucleus and most organelles, allowing more space for haemoglobin molecules (increasing the oxygen carrying capacity of the cell)
- Biconcave disk gives a large surface area to volume ratio, increasing the rate of diffusion
- Small and flexible so they can squeeze through capillaries
- Thin so short diffusion distance

What is the function of white blood cells?

What is the function of white blood cells?

Provide immunological protection

What is the function of platelets?

What is the function of platelets?

Role in blood clotting

What is plasma?

What is plasma?

- Pale-yellow liquid portion of the blood
- Contains proteins, nutrients, waste products, hormones, antibodies etc.

How is plasma adapted to its function?

How is plasma adapted to its function?

Plasma consists mainly of water. This acts as a solvent, enabling the transport of materials around the body.